

1) TOOL TYPE - GERAETETYP - DESCRIZIONE MACCHINA - TYPE D'OUTIL - TIPO DE MAQUINA  
 cod. R31627 HEAD CN-57A

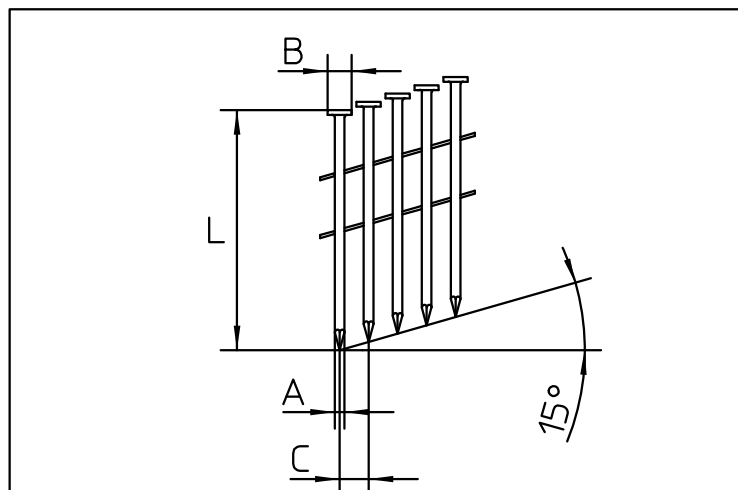
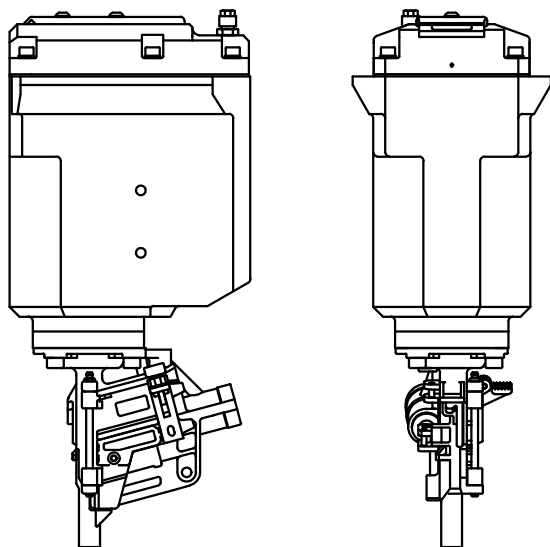

2) TOOL CHARACTERISTICS  
 SPEZIFICATION DES GERAETES  
 CARATTERISTICHE TECNICHE  
 CARACTÉRISTIQUES DE L'OUTIL  
 CARACTERÍSTICAS DE LA MAQUINA

HEIGHT HOEHE ALTEZZA HAUTEUR ALTURA	WIDTH BREITE LARGHEZZA LARGEUR ANCHURA	LENGTH LAENGE LUNGHEZZA LONGUEUR LONGITUD	WEIGHT GEWICHT PESO POIDS PESO
in. 13.15 mm. 334	in. 5.51 mm. 140	in. 6.69 mm. 170	lbs. 12.00 kg. 5.450
MIN-MAX WORKING PRESSURE MIN-MAX ARBEITSDRUCK MIN-MAX PRESSIONE DI ESERCIZIO MIN-MAX PRESSION DE TRAVAIL MIN-MAX PRESSION DE TRABAJO		70 / 120 psi 5 / 8 BAR	
AIR CONSUMPTION PER CYCLE LUFTVERBRAUCH PRO NAGELUNG CONSUMO ARIA PER COLPO CONSOMMATION DE L'AIRE PAR COUP CONSUMO DE AIRE CADA DISPARO		PERFORMANCES AT 90 psi (0.62 MPa) PRESTAZIONI A 6.2 BAR (0.62 MPa) 0.138 SCF 3.90 L.	
LUBRICANT SCHMIEROEL LUBRIFICANTE LUBRIFIANT LUBRIFICANTE		BP ENERGREASE LT2 BP ENERGOL HP10	

3) FASTENER DATA  
 ANGABEN ZU DEN BEFESTIGUNGSMITTELN  
 CARATTERISTICHE TECNICHE FISSAGGI  
 DONNÉES DES PROJECTILES  
 DATOS DE CLAVOS

A) WIRE SCHAFT FILO ALAMBRE TIGE	in. 0.083 - 0.099 mm. 2.1 - 2.5
B) HEAD KOPF TESTA TÊTE CABEZA	in. 0.189 - 0.245 mm. 4.8 - 6.2
C) PITCH TEILUNG PASSO PAS PASO	in. 0.275 - 0.315 mm. 7.0 - 8.0
L) LENGTH LAENGE LUNGHEZZA LONGUEUR LONGITUD	} MIN-MAX in. 1' - 2 1/4' mm. 25 - 57
MAGAZINE CAPACITY MAGAZIN CAPAZITAET CAPACITA' CARICATORE CAPACITE' CHARGEUR CAPACIDAD CARGADOR	

\* ACTUATION SYSTEM - AUSLÖSEART - ATTUAZIONE - MISE EN OEUVRE - ACTUACIÓN

0

\* SEE INSTRUCTION MANUAL - SIEHE BETRIEBSANLEITUNG - VEDI MANUALE - VOIR MODE D'EMPLOI - VER EL MANUAL

NOISE CHARACTERISTICS GERÄUSCH - EMISSION DATEN CARATTERISTICHE RUMOROSITA' CARACTÉRISTIQUES ACOUSTIQUE CARACTERÍSTICAS DE RUIDO	EN 12549+A1:2008 $L_{WA,1s}$ , :98.38 dB(A) - $K_{WA,1s}$ , 2.5
	EN ISO 4871:2009 $L_{pA,1s}$ , :93.00 dB(A) - $K_{pA,1s}$ , 2.5

\* SEE INSTRUCTION MANUAL - SIEHE BETRIEBSANLEITUNG - VEDI MANUALE - VOIR MODE D'EMPLOI - VER EL MANUAL

VIBRATION VALUE VIBRATIONSWERT VALORE DI VIBRAZIONE VALEUR DE VIBRATION VALOR DE VIBRACIÓN	} UNI ISO/TS 8662-11
--	-------------------------