

1) TOOL TYPE - GERAETETYP - DESCRIZIONE MACCHINA - TYPE D'OUTIL - TIPO DE MAQUINA
 cod. 11402 F42 CN15W-45 ROOFING

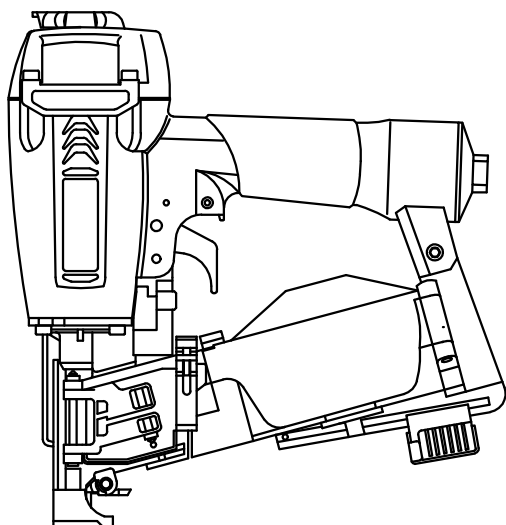

2) TOOL CHARACTERISTICS
 SPEZIFICATION DES GERAETES
 CARATTERISTICHE TECNICHE
 CARACTÉRISTIQUES DE L'OUTIL
 CARACTERÍSTICAS DE LA MAQUINA

HEIGHT HOEHE ALTEZZA HAUTEUR ALTURA	WIDTH BREITE LARGHEZZA LARGEUR ANCHURA	LENGTH LAENGE LUNGHEZZA LONGUEUR LONGITUD	WEIGHT GEWICHT PESO POIDS PESO
in.11.02 mm.280	in.4.33 mm.110	in.10.23 mm.260	lbs.5.18 kg. 2.350
MIN-MAX WORKING PRESSURE MIN-MAX ARBEITSDRUCK MIN-MAX PRESSIONE DI ESERCIZIO MIN-MAX PRESSION DE TRAVAIL MIN-MAX PRESSION DE TRABAJO		70 / 100 psi 5 / 7 BAR	
AIR CONSUMPTION PER CYCLE LUFTVERBRAUCH PRO NAGELUNG CONSUMO ARIA PER COLPO CONSOMMATION DE L'AIRE PAR COUP CONSUMO DE AIRE CADA DISPARO		PERFORMANCES AT 90 psi (0.62 MPa) PRESTAZIONI A 6.2 BAR (0.62 MPa) 0.032 SCF 0.9 L.	
LUBRICANT SCHMIEROEL LUBRIFICANTE LUBRIFIANT LUBRIFICANTE		AEROSPACE LUBRICANTS TRIBOLUBE 12	

* ACTUATION SYSTEM * AUSLÖSEART * ATTUAZIONE * MISE EN ŒUVRE * ACTUACIÓN	3/4 (SAFETY : FS/CT)
--	----------------------

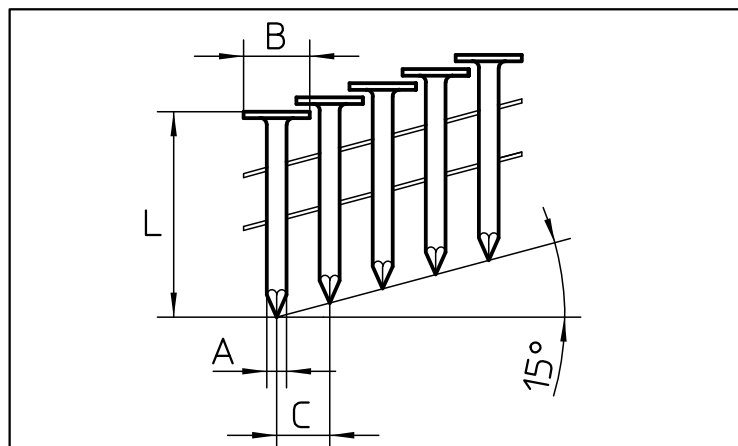

3) FASTENER DATA
 ANGABEN ZU DEN BEFESTIGUNGSMITTELN
 CARATTERISTICHE TECNICHE FISSAGGI
 DONNÉES DES PROJECTILES
 DATOS DE CLAVOS

A) WIRE SCHAFT FILO ALAMBRE TIGE	in. 0.118 mm. 3.0
B) HEAD KOPF TESTA TÊTE CABEZA	in. 0.393 mm. 10
C) PITCH TEILUNG PASSO PAS PASO	in. 0.314 mm. 8.0
L) LENGTH LAENGE LUNGHEZZA LONGUEUR LONGITUD	MIN-MAX in. 3/4' - 1 3/4' mm. 19 - 45
MAGAZINE CAPACITY MAGAZIN CAPAZITÄT CAPACITA' CARICATORE CAPACITÉ CHARGEUR CAPACIDAD CARGADOR	120 nails

* LOADING	BOTTOM LOADING
* LADEN	SIDE LOADING
* CARICAMENTO	TOP LOADING
* CHARGER	● COIL
* CARGA	OTHER

* SEE INSTRUCTION MANUAL - SIEHE BETRIEBSANLEITUNG - VEDI MANUALE - VOIR MODE D'EMPLOI - VER EL MANUAL

NOISE CHARACTERISTICS GERÄUSCH - EMISSION DATEN CARATTERISTICHE RUMOROSITÀ CARACTÉRISTIQUES ACOUSTIQUE CARACTERÍSTICAS DE RUIDO	EN 12549+A1:2008	$L_{WA,1s}$, :97.80 dB(A) - $K_{WA,1s}$, 2.5
	EN ISO 4871:2009	$L_{pA,1s}$, :85.60 dB(A) - $K_{pA,1s}$, 2.5

VIBRATION VALUE VIBRATIONSWERT VALORE DI VIBRAZIONE VALEUR DE VIBRATION VALOR DE VIBRACIÓN	UNI ISO/TS 8662-11	m/s ² 3.89
--	-----------------------	-----------------------